

DENIOS.

System container



System container 2G 614.O with sliding doors

OPERATING INSTRUCTIONS

Mat.-No. 130406 EN BA System container

02/2008

Table of contents:

- 1. General Points 3**
- 2. Intended use 3**
- 3. Product description..... 3**
 - Assembly 3**
- 4. Technical Details 4**
 - 4.1 Explanation of model codes..... 4**
 - 4.2 Tables: Dimensions and load capacities 4**
- 5. Transport..... 6**
- 6.Assembly..... 6**
 - 6.1 Location of the container 6**
 - 6.2 Securing the container to the floor..... 8**
 - 6.3 Assembling the container part by part including the sliding doors 9**
 - 6.3.1 Tools required 9
 - 6.3.2 List of parts to assemble the upper and lower components of the container 9
 - 6.3.3 Lower and upper levels of the container 10
 - 6.3.4 Assembling the upper and lower levels of the container 11
 - 6.3.5 Detailed diagrams of the upper and lower levels picture 1-4..... 11
 - 6.3.6 Over view of the sliding doors..... 14
 - 6.3.7 Parts list for the sliding doors 15
 - 6.3.9 Detailed diagrams of the sliding doors pictures 6 – 11 16
 - 6.4 Earthing the naturally ventilated containers 19**
- 7. Operation..... 19**
 - 7.1 For storage indoors and outdoors 19**
 - 7.2 Advice when dispensing 19**
- 8. Maintenance and Repair 20**
- 9. Spare List 20**
- 10. Optional equipment 20**
- 11 Appendix 21**

Please find general operating instructions and proof of conformity, attached

1. General Points

These operating instructions are applicable to system containers and system containers with natural ventilation. They specify all the information necessary for their correct operation. The advice and instructions mentioned in the booklet are to be observed and adhered to.

If the product is used in accordance with the regulations corresponding to these operating instructions, we will be liable in line with our guarantee conditions.

No modifications or alterations can be made to the product without authorisation from the manufacturer. The manufacturer will not be liable for any modifications made without their authorisation and the guarantee will expire and cease to be valid.

The general instructions for storage systems, material no. 103041, in the current version, must be observed.

National standards and safety regulations must be observed.



It is forbidden for fire or naked flames to be in close proximity to the system container. Smoking is also prohibited.

2. Intended use

System containers with natural ventilation are ideal for the **passive storage** of water hazardous materials and materials included in hazardous materials classifications R10, R11 or R12 in accordance with hazardous materials classifications (also, please see section 3).-



- Only store substances that the sump material is resistant to. See general operating instructions



- Versions equipped with PVC panels or roller doors are not permitted for storage of inflammable liquids

3. Product description

Assembly

The system containers are assembled from the following components:

- Frame construction made from hollow and shaped sections in accordance with static requirements
- Side panels and roof made from galvanized sheet
- Rear panel made from trapezoid profiled sheet
- Sump manufactured from steel S235 JRG2 according to DIN EN 10025
- optional sump insert made from steel or PE
- Optional wing doors, sliding doors, PVC panels or roller doors can be fitted to the front of the container

4. Technical Details

4.1 Explanation of model codes

3 G 3 14. O ST - S (Example)

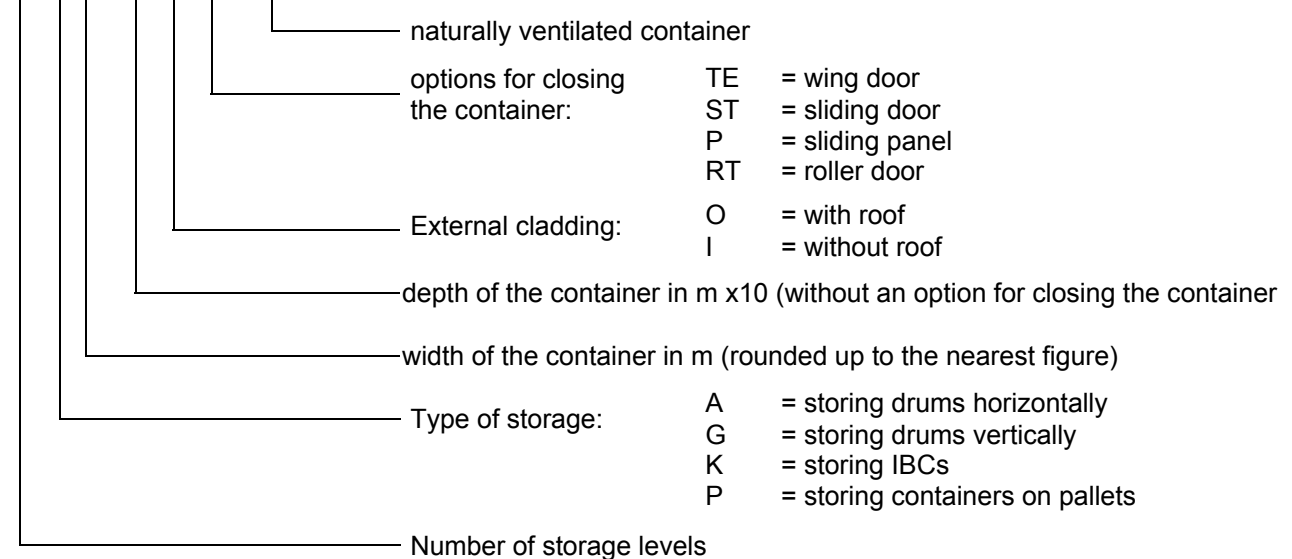

4.2 Tables: Dimensions and load capacities

Standard-System container for storing drums vertically outdoors

Model	Width (mm)	Depth (mm)	Height (mm)	Sump capacity (ltr)	Load capacity (kg/m ²)	Load (kg)
1G 314.O	3000	1310	1 x 2640	750	1000	4200
2G 314.O			2 x 1250			
3G 314.O			3 x 1250			
1G 614.O	2 x 3000		1 x 2640	1500		
2G 614.O			2 x 1250			
3G 614.O			3 x 1250			
1G 326.O	3000	2 x 1270	1 x 2640	1300	3900	
2G 326.O			2 x 1250			
3G 326.O			3 x 1250			
1G 626.O	2 x 3000		1 x 2640	2540		
2G 626.O			2 x 1250			
3G 626.O			3 x 1250			2900

Standard-System container for the external storage of pallets

Model	Width (mm)	Depth (mm)	Height (mm)	Sump capacity (ltr)	Load capacity (kg/m ²)	Load (kg)
2P 414.O	3900	1310	2 x 1250	1100	1000	5460
3P 414.O			3 x 1250			
2P 814.O	2 x 3900		2 x 1250	2100		
3P 814.O			3 x 1250			

OPERATING INSTRUCTIONS

Standard-System container for the external storage of IBCs

Model	Width (mm)	Depth (mm)	Height (mm)	Sump capacity (ltr)	Load capacity (kg/m ²)	Load (kg)
1K214.O 2K214.O	2700	1310	1 x 2570 2 x 1500	1000	1250	4725
1K 414.O 2K 414.O	3380		1 x 2570 2 x 1500	1180		5915
1K 514.O 2K 514.O	2.x.2700		1 x 2570 2 x 1500	2000		4725
1K 714.O 2K 714.O	2 x 3380		1 x 2570 2 x 1500	2400		5915

Standard-System containers and for storing drums horizontally outdoors

Model	Width (mm)	Depth (mm)	Height (mm)	Sump capacity (ltr)	Load capacity (kg/m ²)	Load (kg)
2A 314.O 3A 314.O	3000	1340	2 x 1165 3 x 750	470	350 kg/drum storage space.	
2A 614.O 3A 614.O	2 x 3000		2 x 1165 3 x 750	1000		

Standard-System container for the storing drums vertically indoors

Model	Width (mm)	Depth (mm)	Height (mm)	Sump capacity (ltr)	Load capacity (kg/m ²)	Load (kg)
2G 314.I 3G 314.I	3000	1310	1 x 1250 1 x 500 2 x 1250 1 x 500	750	1000	4200
2G 614.I 3G 614.I	2 x 3000		1 x 1250 1 x 500 2 x 1250 1 x 500	1500		

Compliance: System containers are compliant with construction regulations No. Z-38.5-120.



System containers have also been tested and are approved for the following:

Load capacity: maximum wind resistance: → 0,5 kN/m² in accordance with DIN 1055 Part 4, see Tables: Dimensions and load capacities

Resistance in snowy conditions (roof load): → 0,75 kN /m²

5. Transport



Do only transport when empty!

System containers **without** crane hooks can be loaded and transported with an appropriately sized fork lift truck.

When transporting system containers **with** crane hooks, the angle of the ropes must not be less than 45°. See the "load position" diagram.

- **Load position**

Please note: the ropes in the middle must be taught

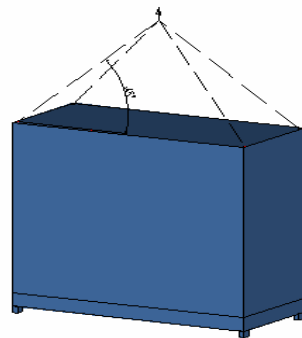

Container models:
314 / 414 / 326 / 426

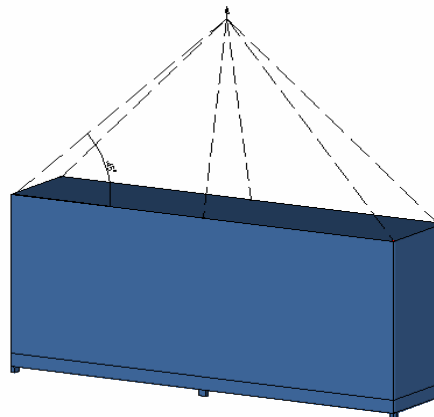

Container models:
614 / 714 / 814 / 626 / 826

6. Assembly

6.1 Location of the container

System containers can only be installed on level and stable surfaces. The whole construction from the sides to the foundation must be designed so that the loads specified can be contained securely. A competent person will decide which type of concrete the container will be installed on taking into account the requirements in the location of the installation; the load capacity, what the container will store and durability in accordance with DIN EN 206 (also please see the foundation plan). Other requirements can be found in the general operating instructions.

- **Correct installation position of the container (indication of the alignment of the door)**

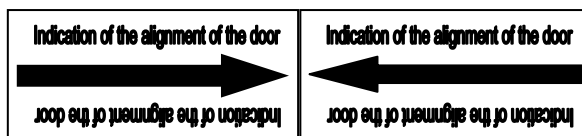

- The signs above will be fixed onto the wing doors in the factory to show the horizontal alignment of the doors
- The arrows show that the doors are aligned
- If the points of the arrows face each other the container is balanced and the doors will open and close correctly.
- If the points of the arrows do not face each other then the doors will not open and close correctly.
- In this situation the container must be supported (for example with spacer plates) to ensure that the

ground beneath the container is no longer uneven and the container can then be balanced

The system container can be installed indoors or outdoors. Please observe and adhere to the following installation instructions (see pictures 1-3).

Picture 1

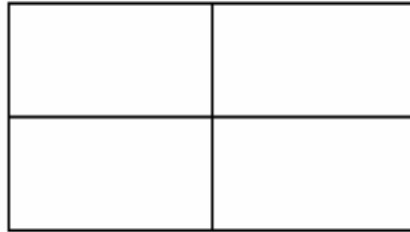

Arranging the containers in a block, max. 4 containers;
2 containers fit together in 2 rows one behind the other!

Picture 2



Containers can be arranged in a row,
no limit on the number of containers!

Picture 3

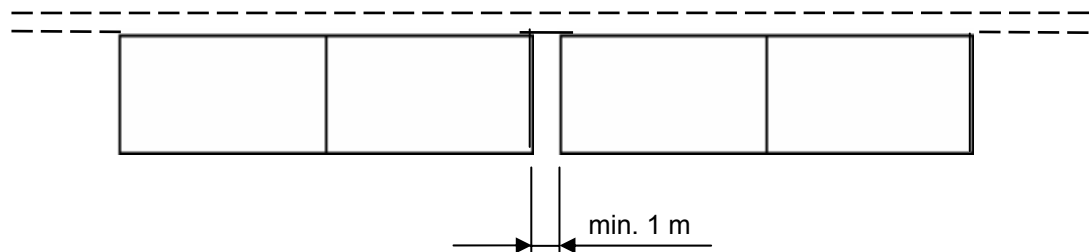

2 containers can be fitted in a row together against a wall!

6.2 Securing the container to the floor

Balance the container using a spirit level. If necessary use supports to balance the container (for example spacer plates). See the diagram "securing foot plates to the ground".

- **Diagram „securing foot plates to the ground“**

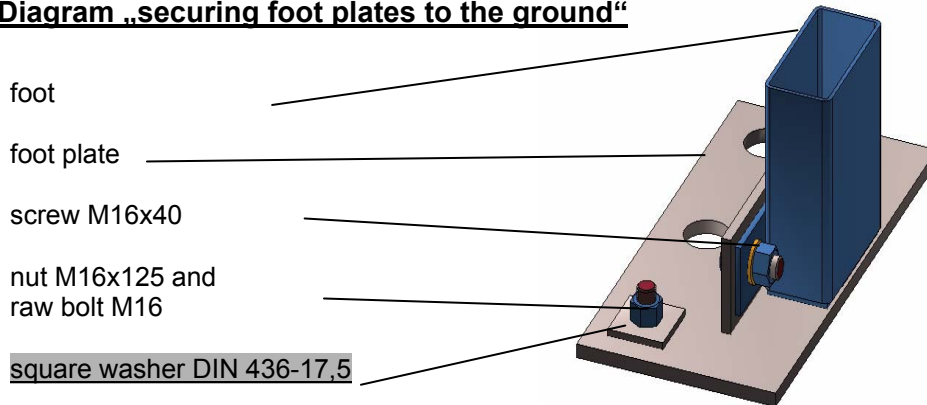

The foot plates are secured in place with the nuts and raw bolts. See pictures 1-3 for the position and quantity of the nuts and raw bolts.

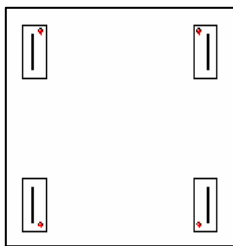

Picture 1

Container models: 314 / 414 / 326 / 426-O and OTE
Quantity of nuts and raw bolts: 4

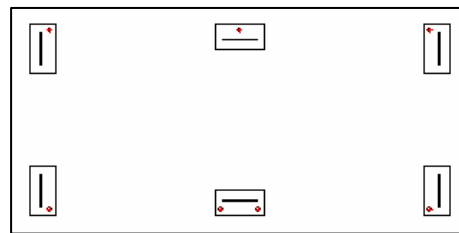

Picture 3

Container models: 614 / 714 / 814 / 626 / 826-OST
Quantity of nuts and raw bolts: 7 - 8

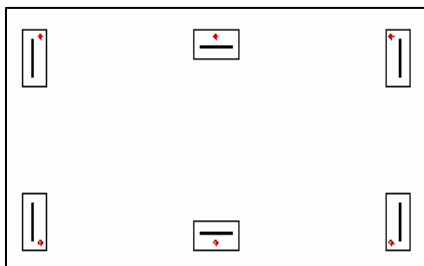

Picture 2

Container models: 614 / 714 / 814 / 626 / 826-O, OTE and ORT
Quantity of nuts and raw bolts: 6

6.3 Assembling the container part by part including the sliding doors

At least 2 people are required to assemble the system container. The ground must be level and suitable for securing the foot plates.

6.3.1 Tools required

- **Fork lift truck with an access safety platform** (for the assembly of the lower level, upper level and the doors)
- **Spirit level** (for aligning the container)
- **Mandrel Ø 12 x 100 mm** (to align the upper and base parts)
- **Combination wrench SW 19 and SW 24** (to tighten screws and dowels)
- **Vice** (2, to hold the panels)
- **Cordless screw driver** (Assembling the panels)
- **Silicone syringes** (Sealing the panels)
- **Hammer drill with masonry drill bit Ø 18 x 200 mm** (Drilling for nuts and raw bolts)

6.3.2 List of parts to assemble the upper and lower components of the container

Pos.	Description	Quantity
1	Lower level of the system container	1
2	Upper level of the system container	1
3	Foot plates	6
4	Side panel	2
5	Rain deflector on the rear panel of the container	2
5.1	Rain deflector on the rear panel of the container	1
6	Hexagonal screw M16 x 40 ISO-4017 (DIN933)	12
7	Hexagonal bolt M16 ISO-4032 (DIN934)	12
8	Washer d=17 ISO-7089/7090 (DIN125)	24
9	nut M16 x 125	7
10	Raw bolt M16 x 190	7
11	Square washer d=17,5 (DIN436)	7
12	Hexagonal screw M12 x 100 ISO-4017 (DIN933)	4
13	Hexagonal bolt M12 ISO-4032 (DIN934)	6
14	Washer d=13 ISO-7089/7090 (DIN125)	8
15	Square washer d=14 (DIN434)	4
16	Hexagonal screw M12 x 160 ISO-4014 (DIN931)	2
17	Self drilling screw 4,8 x 16 (DIN7504)	40

6.3.3 Lower and upper levels of the container

The separated container model 3G 614.O

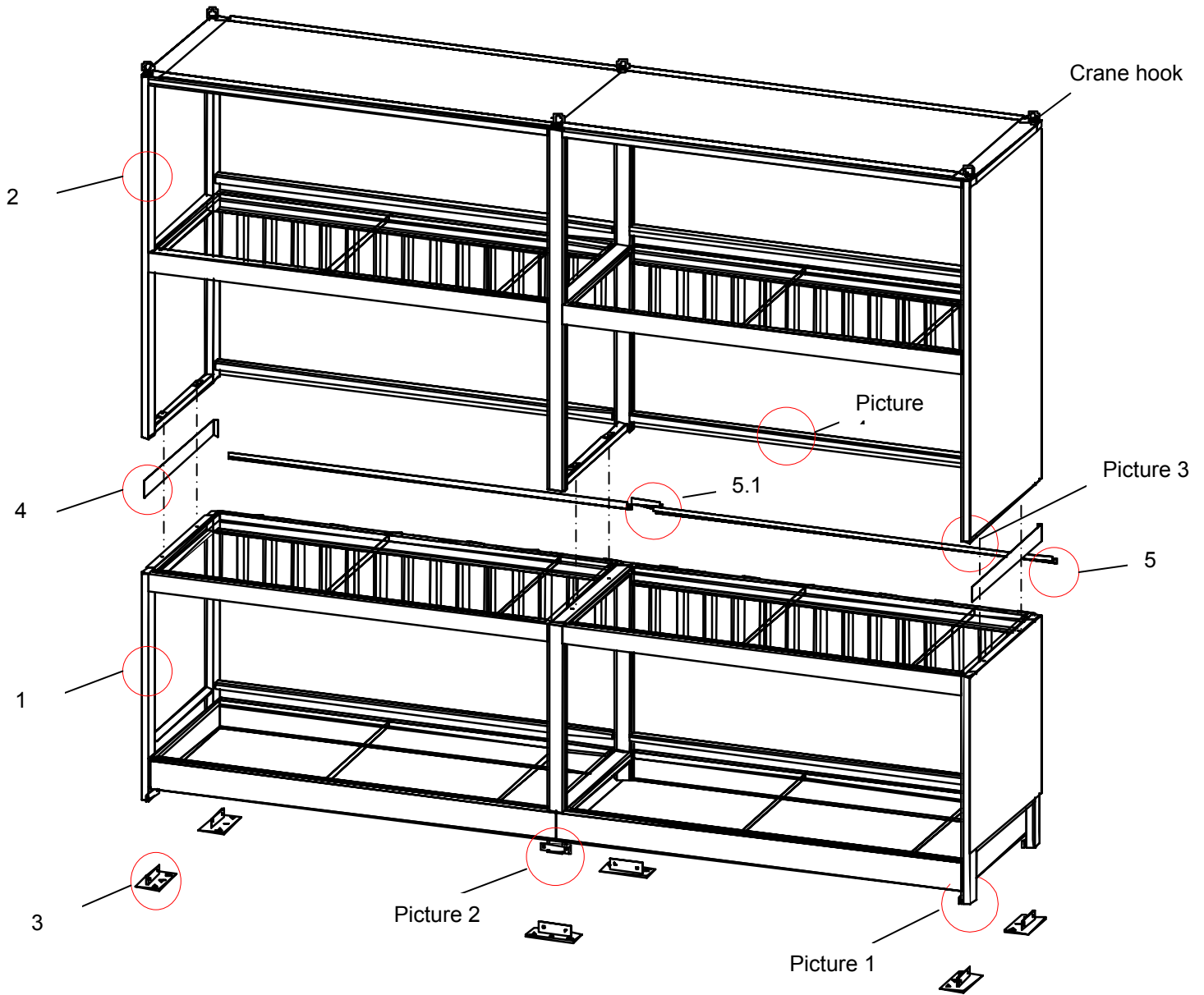

6.3.4 Assembling the upper and lower levels of the container

1. Place the lower level of the container **(1)** on a level, stable surface using a fork lift truck and balance the container using a spirit level. Support the foot plates with spacer plates if required.
2. Place the upper level of the container **(2)** on the lower level with a fork lift truck **(1)** and align with the mandrel.
3. Screw the left and right side frames and the middle frame together with hexagonal screws **(12, 13, 14, 15 und 16)**, (see **picture 3** „Screwing the upper and lower levels together“).
4. Push the rain deflector on the rear panel of the container **(5 and 5.1)** behind the trapezoid profile of the upper level. Assemble the short rain deflector in the middle of the container, both the 3 metre long panels should overlap at approx. 30mm Place the rain deflector on the trapezoid profile using self drilling screws **(17)**. Screw the self drilling screws **(17)**, (see **picture 4** „rear rain deflector“).
5. Screw the side panels **(4)** on the outer side of the right and left hand sides of the container with self drilling screws **(17)**, (see **picture 3** „Screwing the upper and lower levels together“).
6. Seal the upper edges of the side panels with silicone.
7. Dowel the foot plates **(3)** with the nuts and raw bolts **(9, 10 und 11)** together in accordance with the manufacturer's specifications, (see **picture 1** „foot plate“).
8. Containers with sliding doors are supported at the front by 2 feet and nuts and raw bolts, (see **picture 2** „centre of the footplate“ and point 6.2 „securing the container to the floor“).

6.3.5 Detailed diagrams of the upper and lower levels picture 1-4

Picture 1 „Foot plate“

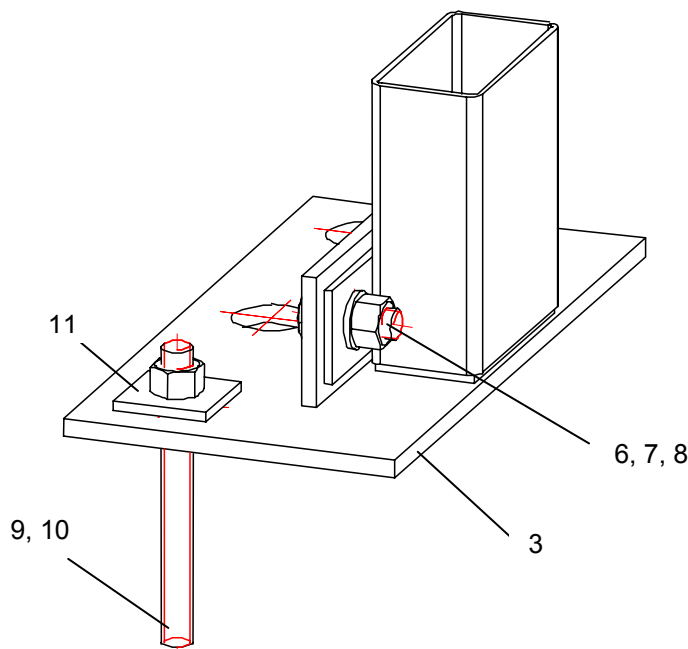

Picture 2 „Centre of the foot plate“

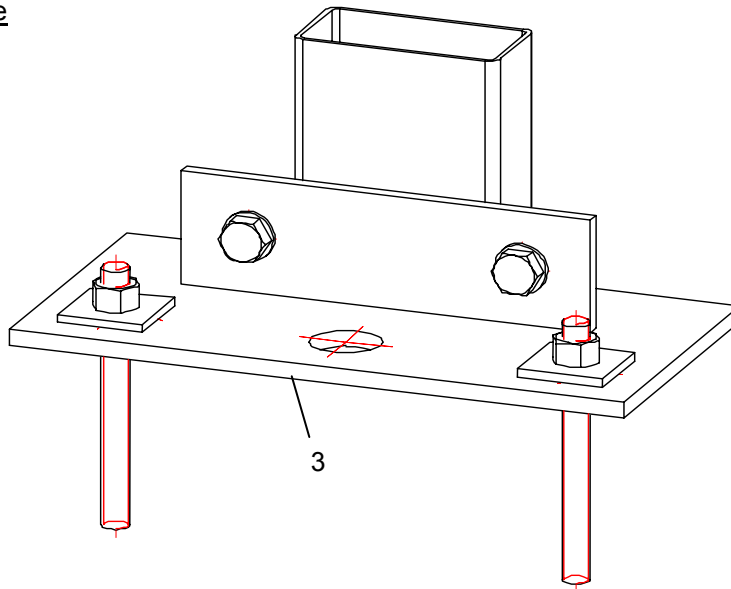

Picture 3 „Screwing the upper and lower levels together“

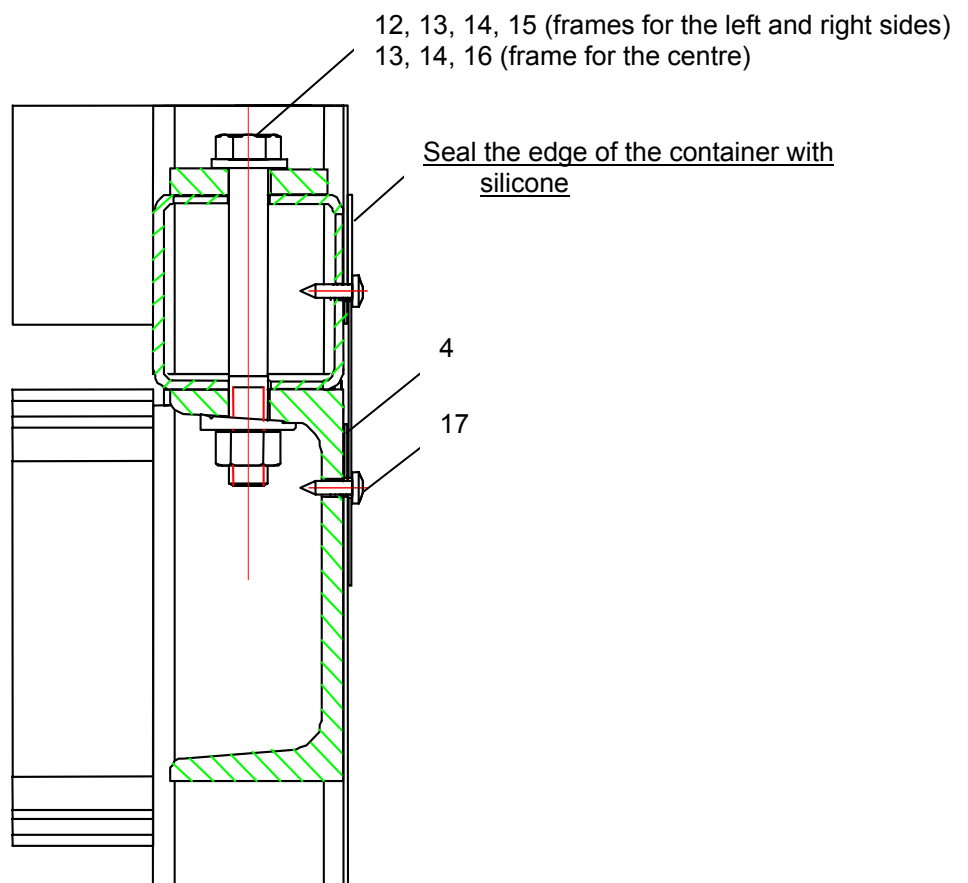

Picture 4 „rear rain deflector“

Trapezoid profile

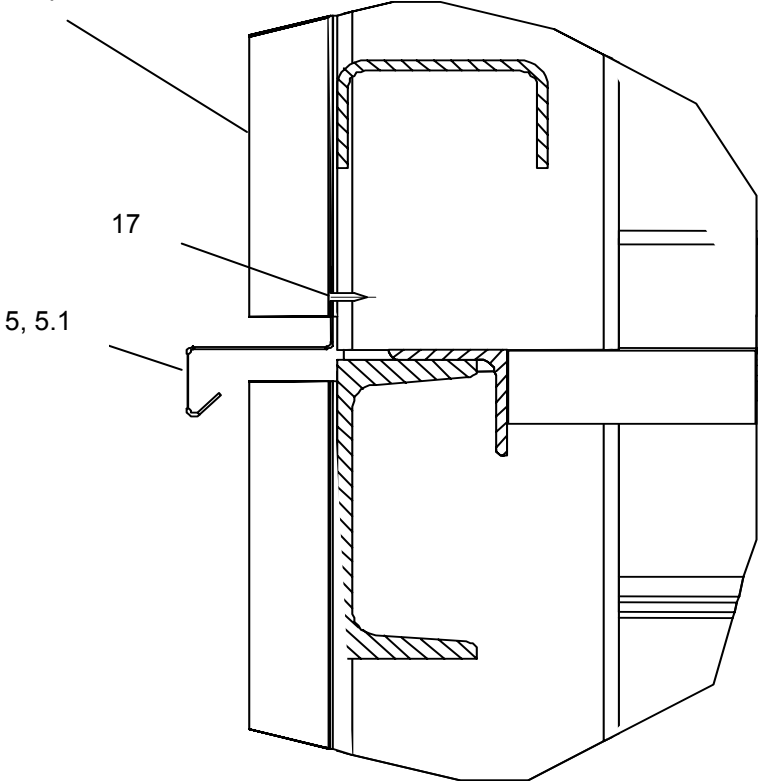

6.3.6 Over view of the sliding doors

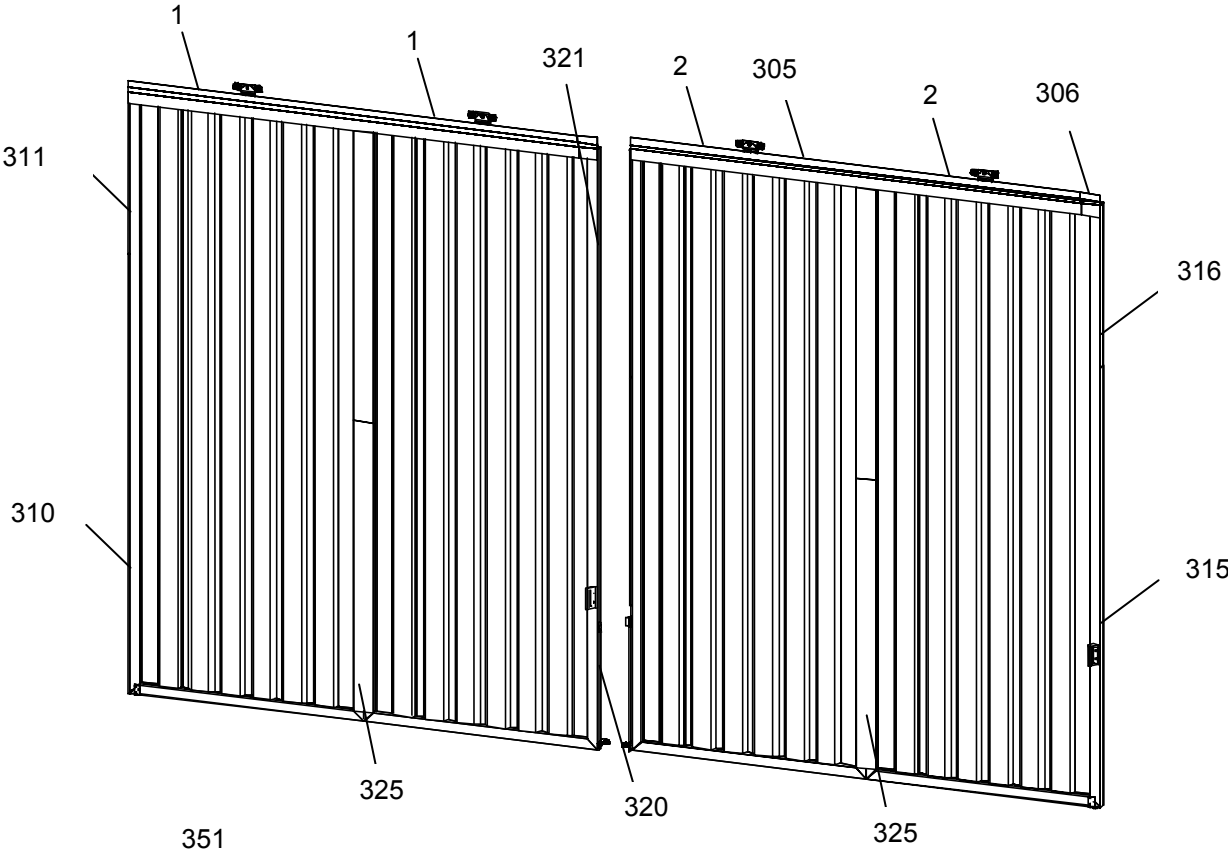

351
(self drilling screws \varnothing 6,3 x 19
approx. every 300 mm)

6.3.7 Parts list for the sliding doors

Pos.	Bezeichnung	Stückzahl
1	Left sliding door panel (for the front runner)	1
1	Left sliding door panel (for the front runner)	1
2	Right sliding door panel (for the back runner)	1
2	Right sliding door panel (for the back runner)	1
18	Plate for holding the left door stopper	1
19	Locking plate for the sliding door	1
20	Bracket for the central sliding door stop	2
21	Bracket for the right sliding door stop	1
22	Bracket for the left sliding door stop	1
305	Cladded face plate for sliding doors (all models)	2
306	Cladded face plate for sliding doors (model G 614.O)	2
310	Sliding door face plate on the left model 3G / 3P	1
311	Sliding door face plate on the left model 3G / 3P	1
315	Sliding door face plate on the right model 3G / 3P	1
316	Sliding door face plate Re / Lock model 3G / 3P	1
320	Face plate for the lower door lock	1
321	Face plate for the upper door lock	2
325	Bars for the doors 1982 lg	4
351	Hexagonal screw 6,3 x 19-K, galvanized., (DIN 7504)	50
410	Roller mechanism	4
411	Guide roller	2
412	KST - runner	2
413	Black synthetic handle	2
414	Clamp for the swing bolt	1
415	cylinder	1
416	WSS-plate around the keyhole	1
417	Door stopper H=35 D=40	1
512	washer 6,4 x 20	2
513	Hexagonal screw M 6 x 40 ISO 4017	1
514	Acorn nut M 6	1
516	Countersunk screw M 5 x 16 ISO 7046	4
517	Countersunk self drilling screw 6,3 x 25-K, galvanized., (DIN 7504)	14
518	Internal cylinder screw 6kt. M 6 x 20	4
520	Cross self drilling screw 4,8 x 19-N, galvanized, (DIN 7504)	40
521	Flat headed screw with a groove	2

6.3.8 Assembling the sliding doors

1. Screw the roller mechanism (410) into the left (1) and right (2) door panels. The head of the screw should have approx. 35mm gap from the door, (see **picture 6** „Sliding door roller mechanism“).
2. Guide the roller mechanism (410) into the runners.
3. **Please note:** The bracket needs to face outwards!
4. Hang the right (2) and left (1) door panels onto the roller mechanism. Firstly, hang the right door panel (2) on the back runner and then the left door panel (1) on the front runner.
5. Balance the doors and adjust the roller mechanism.
6. Put the door together using the bars for the doors (325) and the self drilling screws (351), (see „Overview of the sliding doors“). Screw the self drilling screws (351) in at intervals of 300 mm.
7. Fix the left, right and centre sliding door guide rollers in place, (see **picture 7** „sliding door guide roller bottom centre“, **picture 8** „sliding door guide roller bottom right“ and **picture 9** „sliding door guide roller bottom left“).
8. **Please note!** Fix the brackets for the right (21) and left (22) sliding door stop at intervals of 38mm on the front edge of the door!
9. Put the locking plate for the sliding door (19) on the right door panel (2), (see **picture 11** „central lock for the sliding doors“).
10. Put the clamp for the swing bolt (414), handle (413), cylinder (415) and WSS plate around the keyhole (416) together.
11. Assembling the sliding door stoppers (417), (see **picture 10** „ left sliding door stopper“). The stopper needs to be fixed in place centrally at a height of 1500 mm.
12. Assemble the horizontal face plates for the door (305 und 306) and the vertical face plates for the door (315, 316, 320 und 321) as shown in the „overview of the sliding doors“.

6.3.9 Detailed diagrams of the sliding doors pictures 6 – 11

Picture 6 „Roller mechanism“

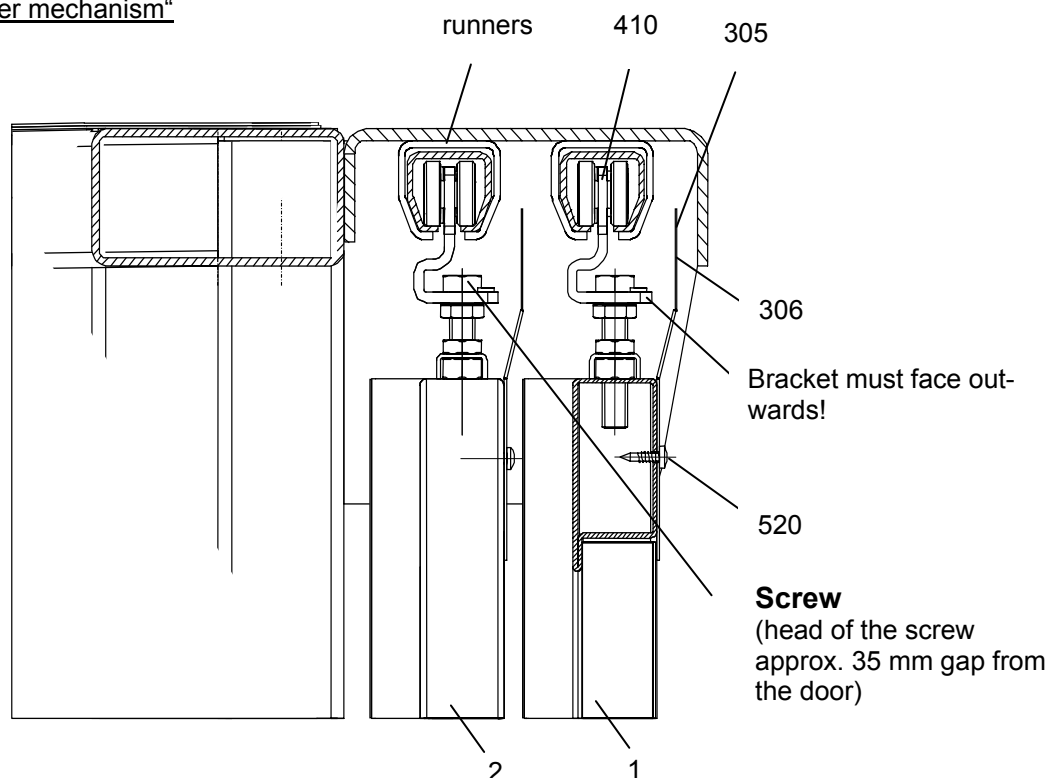

Picture 7 „Sliding door guide rollers bottom left“

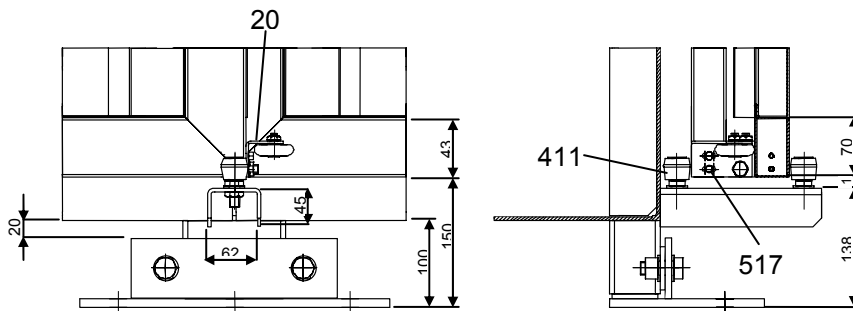

Picture 8 „Sliding door guide roller bottom right“

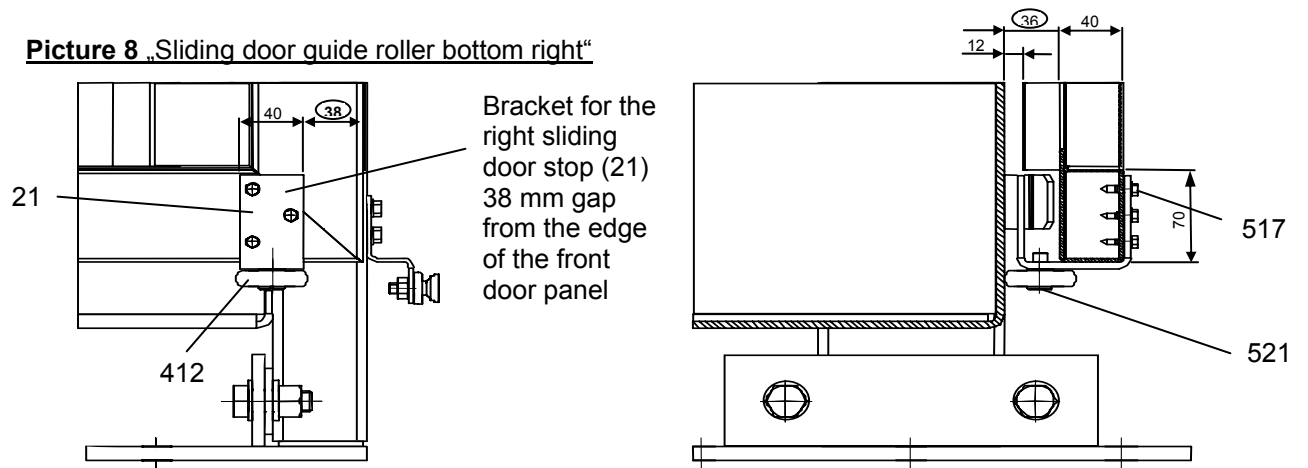

Picture 9 „Sliding door guide roller bottom left“

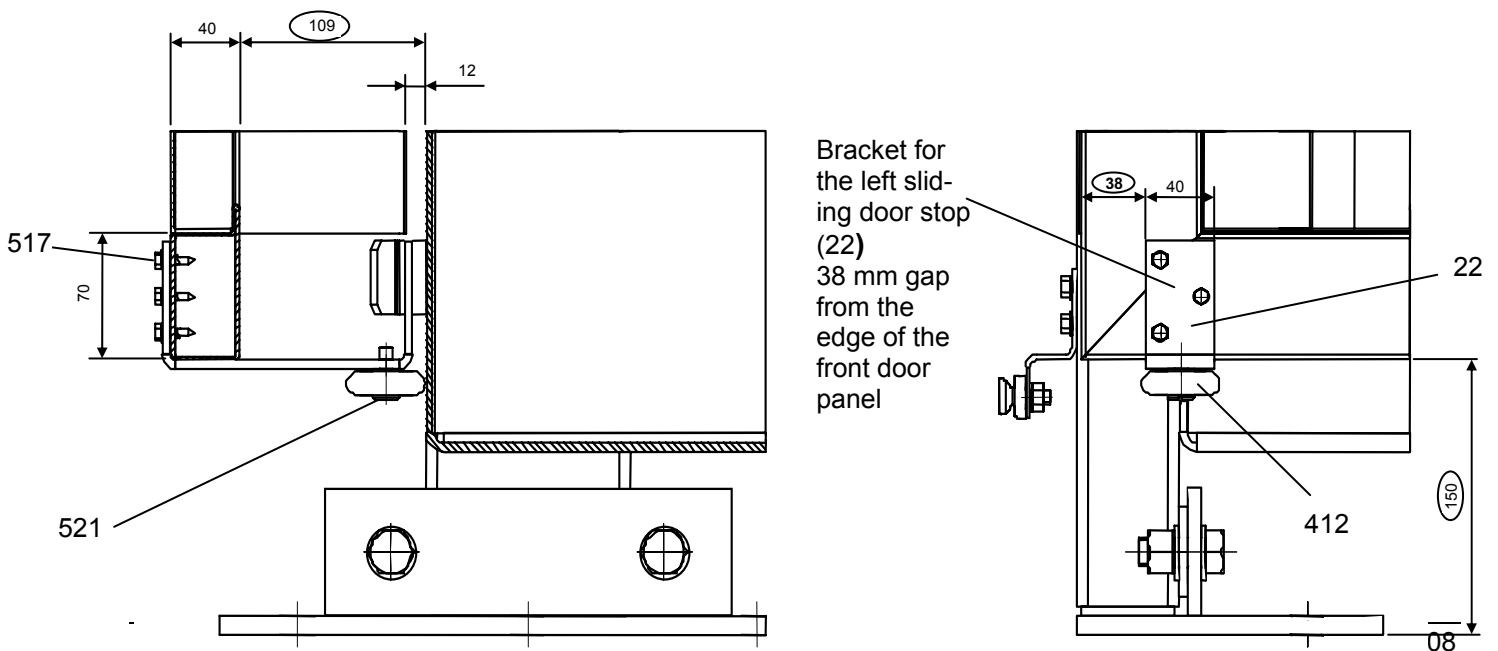

Picture 10 „Stopper for the left sliding door“

Right door panel opened!

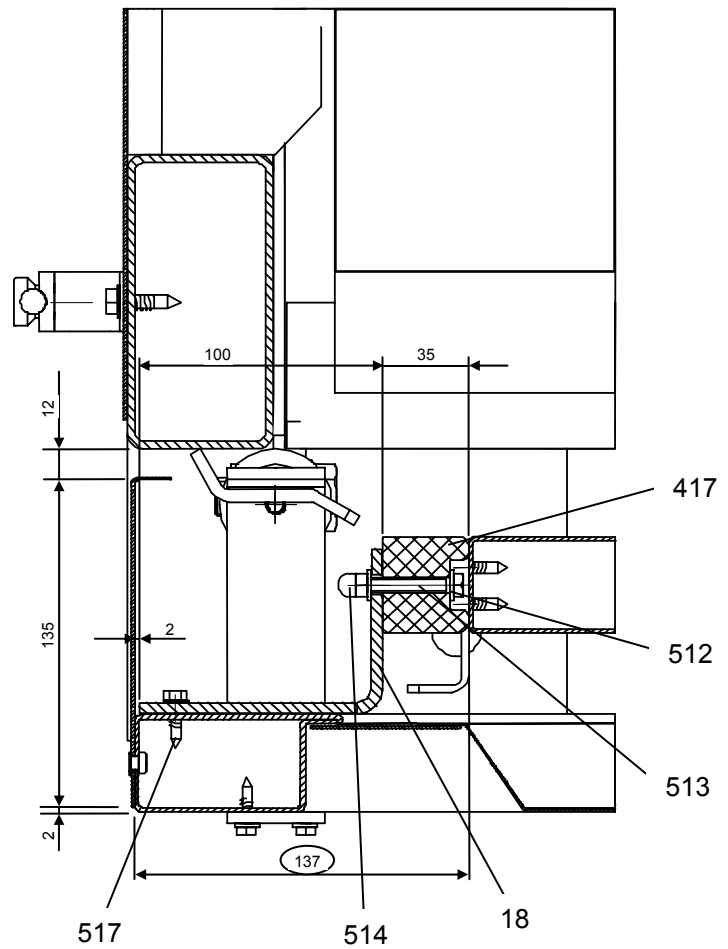

Picture 11 „central lock for the sliding doors“

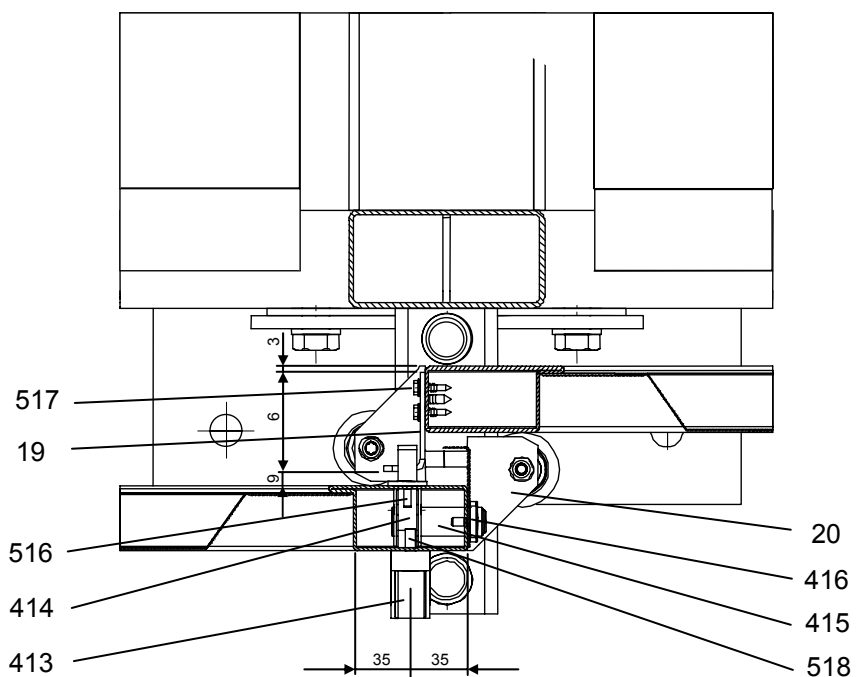

6.4 Earthing the naturally ventilated containers

Naturally ventilated containers must be earthed, when storing flammable liquids (see diagram „Earthing“). Use for this the VbF accessory set (item no.: 138099).

The earth provided by the customer is to be connected to the Vbf accessory set. This contains a suitable earthing link for round steel.



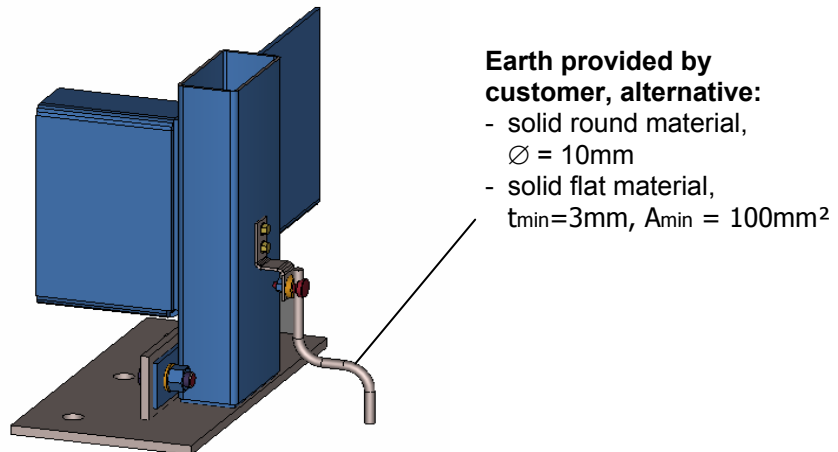

- **Diagram of the earthing**



7. Operation

7.1 For storage indoors and outdoors

After opening the doors, the goods to be stored can be put into and taken out of the system container using the appropriate resources.

-  - Due to the electrostatic earthing; it is essential to remove the protective synthetic packaging around the grid used during transportation!
-  - The system container prevents drums, IBCs etc. from falling. Containers must only be removed from the system container with the correct equipment (for example drum gripper).
-  - When lifting small containers, drums, IBCs etc. ensure adherence to vehicle transportation and work safety regulations, where the lifting height must not exceed 1.5m.
-
-  - The maximum load capacity must not be exceeded (see Table 1: dimensions and load capacities).
-
-  - When storing metal containers, exercise caution when placing them on the grid (speed ≤ 1 m/s) to prevent sparking!

7.2 Advice when dispensing

- Containers should only be opened to fill or empty them.
- When dispensing from containers (for example drums stored horizontally with a tap), the handling area must also be protected by the sump.
- Dispensing containers (for example jugs) must not protrude over the edge of the sump.

8. Maintenance and Repair

- The testing and maintenance of the system container should be carried out in accordance with the general operating instructions, delivered inside the system container.
- Grids, doors and sumps should be tested at regular intervals under regulation compliant conditions.
- Test the earthing cable and earthing equipment regularly, at least every 6 months
- When parts need to be changed, only the original spare parts supplied by the manufacturer must be used!
- **Resistance in snowy conditions (roof load)** is 0,75kN/m².
For example: A resistance to snowy conditions of 0,75kN/m² is equivalent to approx. 25cm of snow; anything above this needs to be cleared.

9. Spare List

Pos.	Description	Model / Size	Art. No.:
1	Grid	1265 x 1285 mm	105445
2	Grid	1265 x 375 mm	105478
Container with Sliding doors:			
3	Synthetic handle	Nr.1095-05	103849
4	Clamp for the swing bolt	Typ 1436	126942
5	Cylinder	RN 8610DOM PZ89/BL45	103840
6	Roller	HBS 433/4610	103690
Container with wing doors:			
7	Barrel for wing door lock	35 mm Dorn	103884
8	Door handle	3110-8 mm bolt	103757
9	Cabin hook	400 mm	103534

10. Optional equipment

Equipment	Description	Art. – No.
earthing accessory set	Essential when storing flammable liquids	138099

11 Appendix

DEUTSCHES INSTITUT FÜR BAUTECHNIK Anstalt des öffentlichen Rechts

10829 Berlin, 18. Juli 2006
Kolonnenstraße 30 L
Telefon: 030 78730-370
Telefax: 030 78730-320
GeschZ.: I 53-1.38.5-17/06

Allgemeine bauaufsichtliche Zulassung

Zulassungsnummer:

Z-38.5-120

Antragsteller:

DENIOS AG
Dehmer Str. 58-64
32549 Bad Oeynhausen

Zulassungsgegenstand:

Systemcontainer mit integrierten Auffangwannen aus Stahl

Geltungsdauer bis:

31. Juli 2011

Der oben genannte Zulassungsgegenstand wird hiermit allgemein bauaufsichtlich zugelassen.
Diese allgemeine bauaufsichtliche Zulassung umfasst zehn Seiten und eine Anlage mit sechs
Seiten.





Schweißtechnische Lehr- und Versuchsanstalt SLV Duisburg - Niederlassung der GSI mbH

Bescheinigung Klasse D

über die Herstellerqualifikation zum Schweißen von Stahlbauten nach DIN 18800-7: 2002-09

Dem Unternehmen **DENIOS AG**
wird für den Schweißbetrieb in **32549 Bad Oeynhausen, Dehmer Straße 58 - 66**

bescheinigt, dass er über die erforderlichen Fachkräfte und Vorrichtungen verfügt, Schweißarbeiten zur Herstellung tragender Stahlbauteile im folgenden Anwendungsbereich durchzuführen:

Normen/Regelwerke	DIN 18800-7
Schweißprozesse (Ordnungsnummer nach DIN EN ISO 4063)	111 Lichtbogenhandschweißen 135 Metall-Aktivgasschweißen teilmechanisiert
Grundwerkstoffe	S235, S275, S355 nach der jeweils gültigen Bauregelliste und der Anpassungsrichtlinie Stahlbau
Erweiterungen/Einschränkungen	keine
Verantwortliche Schweißaufsichtsperson (Name, Vorname, Geburtsdatum, Qualifikation)	Dipl.-Ing. Heumann, Carsten, geb. am 08.07.1957, SFI (DVS)
Vertreter (Name, Vorname, Geburtsdatum, Qualifikation)	entfällt
Bemerkungen	s. Rückseite
Gültigkeitszeitraum	vom 18.06.2008 bis 18.06.2011
Bescheinigungs-Nr.	2008.0108
ausgestellt am	07. Oktober 2008 Lammers/Ms
Leiter der Prüfstelle (Name, Unterschrift, Stempel)	
Allgemeine Bestimmungen siehe Rückseite	

Allgemeine Bestimmungen

1. Diese Bescheinigung ist vor der Ausführung von Schweißarbeiten in beglaubigter Abschrift oder Ablichtung den für die Baugenehmigung zuständigen Behörden unaufgefordert vorzulegen.
2. Zu Werbungs- und anderen Zwecken darf diese Bescheinigung nur im Ganzen vervielfältigt oder veröffentlicht werden. Der Text von Werbeschriften darf nicht im Widerspruch zu dieser Bescheinigung stehen.
3. Ein Ausscheiden der in dieser Bescheinigung für die Wahrnehmung der Aufgaben der Schweißaufsicht genannten Person(en) sowie Änderungen der Schweißverfahren oder wesentlicher Teile der für die Schweißarbeiten notwendigen betrieblichen Einrichtungen sind der anerkannten Prüfstelle rechtzeitig anzuzeigen. Die anerkannte Prüfstelle kann erforderlichenfalls eine erneute Prüfung im Schweißbetrieb veranlassen.
4. Treten Zweifel an der Eignung des Betriebes auf, sind jederzeit unangemeldete kostenpflichtige Betriebsbesichtigungen und Prüfungen im Betrieb durch die anerkannte Prüfstelle vorbehalten.
5. Diese Bescheinigung kann jederzeit mit sofortiger Wirkung entschädigungslos zurückgenommen, ergänzt oder geändert werden, wenn die Voraussetzungen, unter denen sie erteilt worden ist, sich geändert haben, oder wenn die Bestimmungen dieser Bescheinigung nicht eingehalten werden.
6. Mindestens zwei Monate vor dem Ablauf der Geltungsdauer ist bei der anerkannten Prüfstelle erneut ein Antrag zu stellen, falls die Eignung weiterhin bescheinigt werden soll.

Bemerkungen: Die Voraussetzungen zur Durchführung von Schweißer- und Bedienerprüfungen nach Element 1310 liegen vor für
Herrn Carsten Heumann

Zur Unterstützung der Schweißaufsicht wird benannt:
Grosse, Walter, geb. am 27.11.1950, SFM (DVS)

Verteiler:

1. Antragsteller
(Original)

Control- and maintenance-plan *										
DENIOS										
Object	Activity	Instruction / Basis	First-examiner	with demand	2 x weekly	monthly	quarter annually	half annual	annual	all 5 years
Control-system > 1000 AJ bzw. 5000 AJ/IS	Examination before putting into service	BSV, TRGF 20, TRGF 600 IF	Expert	Expert						
Interception trough	Pre-examination of the manufacture-production	Design examination	Expert							
Interception trough	Views on dryness controls, records	LAMA	Manufactured		Operators					Operators
Interception trough	Checks	WHS §19)								
Interception trough	Surface-protection repairs	WHS §19)		Operators						
Interception trough	Damages repair	WHS §19)		Operators						
Fence-rail	controls	WHS §19)	Operators	Operators					Operators	
Fence-identification	controls	BSV	Operators	Operators					Operators	
Fence-rail	exchanges	BSV		Operators					Operators	
Mounting shelf	Controls, especially hook-connection and screws	BSV							Operators	
Mounting shelf	Surface-Protection repairs	BSV							Operators	
Wing-door	controls, especially joints,	BSV							Operators	
Wing-door hinge	hinges, joints	BSV							Expert	
Wing-door hinge	gibs	BSV							Expert	
Wing-door clamp-installation	controls, especially close-function, close-follower	BSV	Manufactured						Expert	
Gate-determine installation	controls	BSV / Permission				Operators			Expert	
Technical ventilation	controls	BSV / BGR 104				Operators			Operators	
Technical ventilation lock up appliance	controls	according to operating instructions							Operators	
Fire-recognition	controls	DIN VDE 0833 / VdS					E-Specialist		Expert	
C02-Detect-installation	Examination, controls	VDE / VdS	Expert						Expert	
C02-Detect-installation	Maintenance	DIN 0703 Teil 1 / VDE A/dS						Qualified employee		
C02-installation	First-examination, record	BSV / BGR 000, Kap. 2.36	Expert							
C02-installation	Heat-exchangers clean, refrigerant-ent	BSV / BGR 000, Kap. 2.36		Operators						
Electric installation entire	First-examination	BSV A3 / BSV / VDE	E-Specialist							E-Specialist
Electric installation entire	Repetition-examination	BSV A3 / BSV / VDE								E-Specialist
Lighting-protection-installation	First-examination	VDE 0181 / BSV	E-Specialist							E-Specialist
Lighting-protection-installation	Repetition-examination	VDE 0181 / BSV								E-Specialist

* The stated maintenance and test intervals are requests. The necessary intervals for the official editions, business-conditions, manufacture-statements, normal rates, that are to be tested from the operator and to keep



DENIOS AG

Dehmer Straße 58-66

32549 Bad Oeynhausen

Tel.: +49 (0)5731 7 53 – 0

Fax: +49 (0)5731 7 53 – 197

E-Mail: info@denios.com

Ihren lokalen Ansprechpartner finden Sie auf unserer Internetseite www.denios.com

You'll find your local partner on our InterNet side www.denios.com

Vous trouverez le nom de votre interlocuteur sur notre site internet www.denios.com

En nuestra página web encontrará usted la persona de contacto correspondiente www.denios.com